

# Renault Master Luton Van



Learn more online: [www.ingimex.com/Luton-Vans](http://www.ingimex.com/Luton-Vans)

  
**INGIMEX**

# Renault Master Luton Van

Designed for dry freight or secure loads, the Ingimex Luton van has a market leading payload and designed to EN12642 XL & EN12640.

Designed and tested to the latest European standards, fitted with an array of features as standard, and easily adapted to allow for the addition of a tail-lift; the Ingimex Luton van is the perfect partner for your Renault Master chassis.



DESIGNED, MANUFACTURED AND TESTED IN THE UK



COMES WITH A 3 YEAR INGIMEX WARRANTY AS STANDARD

Cab Style	Single
Frame length	L3
Rear Wheel	SRW
(X) Wheelbase (mm)	4332
(A) Internal Length (mm)	4119
(B) Internal Width (mm)	1951
(B) External Width (mm)	2100
(C) Internal Height (mm)	2120
(D) Aperture Height (mm)	1770
(E) Overall Length (mm)	6767
Body Weight (kg)	640

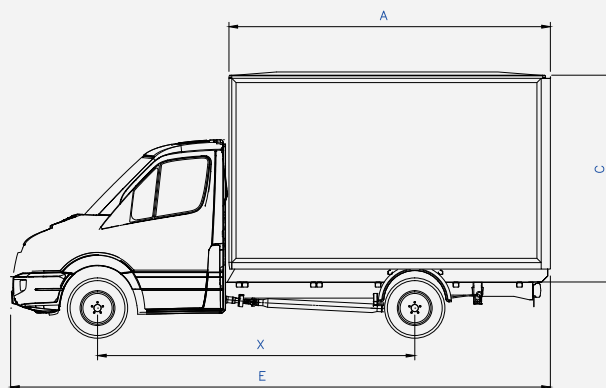
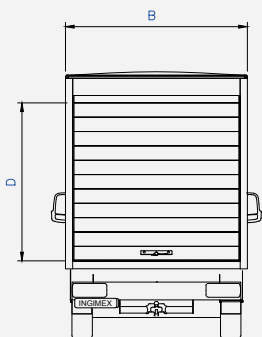

Learn more online: [www.ingimex.com/luton-vans](http://www.ingimex.com/luton-vans)

Wide range of optional extras available

Our Luton bodies support a wide range of bolt-on modifications to suit your needs.

[www.ingimex.com/options](http://www.ingimex.com/options)



[www.ingimex.com](http://www.ingimex.com) ☎ +44 (0) 1952 585 833 ✉ [sales@ingimex.com](mailto:sales@ingimex.com)

