

Peugeot Boxer Tipper



Learn more online: www.ingimex.com/tippers

INGIMEX

Peugeot Boxer Tipper

Suitable for both carrying and tipping loads, the Ingimex tipper is a lightweight, high strength body with a market leading payload and designed to EN12642 XL & EN12640.

Suitable for carrying and tipping of loose loads, the Ingimex tipper is a lightweight but robust body with a high payload, available to fit a variety of Peugeot Boxer chassis cabs and chassis crew cabs, see the table beneath for more detail and dimensions.



DESIGNED, MANUFACTURED AND TESTED IN THE UK



COMES WITH A 3 YEAR INGIMEX WARRANTY AS STANDARD

Cab Style	Single	Double
Frame length	L2	L3
Rear Wheel	SRW	
(X) Wheelbase (mm)	3450	4035
(A) Internal Length (mm)	2870	2670
(B) Internal Width (mm)	2026	2026
(B) External Width (mm)	2087	2087
(C) Sideboard Height (mm)	400	400
(D) Tail-board Height (mm)	600	600
(E) Overall Length (mm)	5859	6100
Body Weight (kg)	490	470

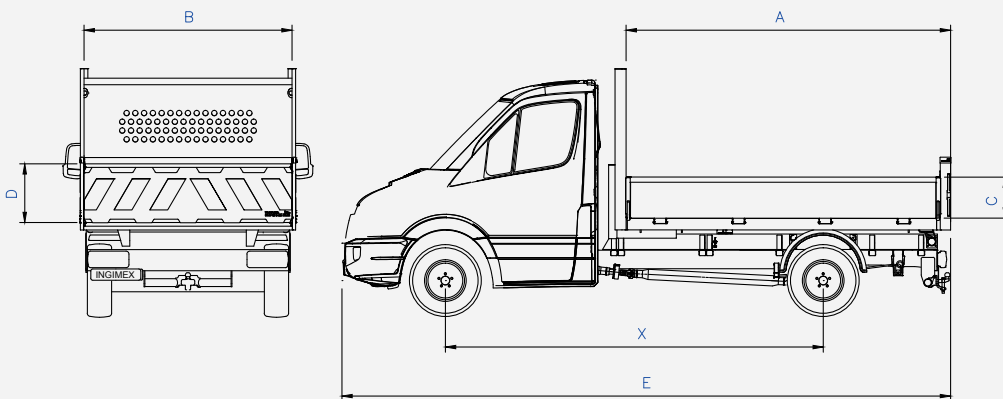

Learn more online: www.ingimex.com/tippers

Wide range of optional extras available

Our Tipper bodies support a wide range of bolt-on modifications to suit your needs

www.ingimex.com/options



www.ingimex.com ☎ +44 (0) 1952 585 833 ✉ sales@ingimex.com

