

# Peugeot Boxer Dropside



Learn more online: [www.ingimex.com/dropsides](http://www.ingimex.com/dropsides)

  
**INGIMEX**

# Peugeot Boxer Dropside

Suitable for general freight, the Ingimex Dropside is a low cost, lightweight, high strength body with a market leading payload designed to EN12642 XL & EN12640.

Designed and tested to the latest European standards, fitted with an array of features as standard, and easily adapted to allow for the addition of optional modifications; the Ingimex dropside is the perfect partner for your Peugeot Boxer chassis.



DESIGNED, MANUFACTURED AND TESTED IN THE UK



COMES WITH A 3 YEAR INGIMEX WARRANTY AS STANDARD

Cab Style	Single			Double
	L2	L3	L4	L3
Frame length				
Rear Wheel	SRW			
(X) Wheelbase (mm)	3450	4035	4035EF	4035
(A) Internal Length (mm)	3059	3644	4009	2805
(B) Internal Width (mm)	2026	2026	2026	2026
(B) External Width (mm)	2087	2087	2087	2087
(C) Sideboard Height (mm)	400	400	400	400
(D) Tail-board Height (mm)	400	400	400	400
(E) Overall Length (mm)	5645	6229	6594	6229
Body Weight (kg)	281	333	356	265

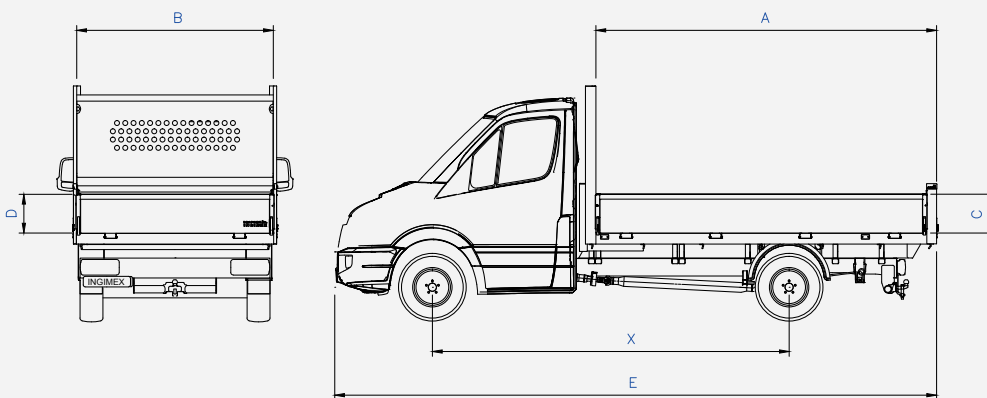

Learn more online: [www.ingimex.com/dropsides](http://www.ingimex.com/dropsides)

Wide range of optional extras available

Our Dropside bodies support a wide range of bolt-on modifications to suit your needs.

[www.ingimex.com/options](http://www.ingimex.com/options)



[www.ingimex.com](http://www.ingimex.com) ☎ +44 (0) 1952 585 833 ✉ [sales@ingimex.com](mailto:sales@ingimex.com)

