

Nissan NV400 Dropside



Learn more online: www.ingimex.com/dropsides

INGIMEX

Nissan Dropside

Suitable for general freight, the Ingimex Dropside is a low cost, lightweight, high strength body with a market leading payload designed to EN12642 XL & EN12640.

Designed and tested to the latest European standards, fitted with an array of features as standard, and easily adapted to allow for the addition of optional modifications; the Ingimex dropside is the perfect partner for your Nissan NV400 chassis.



DESIGNED, MANUFACTURED AND TESTED IN THE UK



COMES WITH A 3 YEAR INGIMEX WARRANTY AS STANDARD

Cab Style	Single				Double		
	L2	L2	L3HD	L3	L2	L3HD	L3
Frame length	L2	L2	L3HD	L3	L2	L3HD	L3
Rear Wheel	SRW	DRW		SRW	DRW	SRW	SRW
(X) Wheelbase (mm)	3682	3682	3682	4332	3682	3682	4332
(A) Internal Length (mm)	3260	3260	3813	3910	2510	3062	3159
(B) Internal Width (mm)	2026	2026	2026	2026	2026	2026	2026
(B) External Width (mm)	2087	2087	2087	2087	2087	2087	2087
(C) Sideboard Height (mm)	400	400	400	400	400	400	400
(D) Tail-board Height (mm)	400	400	400	400	400	400	400
(E) Overall Length (mm)	5928	5928	6478	6578	5928	6548	6578
Body Weight (kg)	251	251	281	286	212	241	246

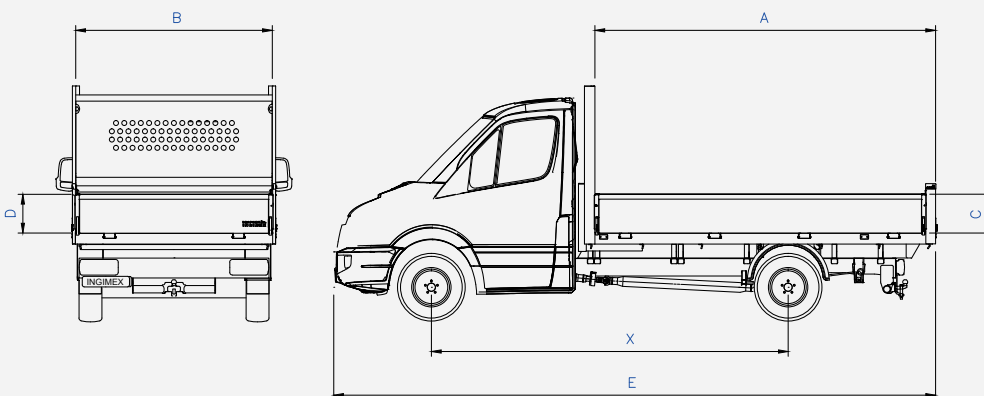

Learn more online: www.ingimex.com/dropsides

Wide range of optional extras available

Our Dropside bodies support a wide range of bolt-on modifications to suit your needs.

www.ingimex.com/options



www.ingimex.com ☎ +44 (0) 1952 585 833 ✉ sales@ingimex.com

