

# Mercedes Sprinter Tipper



Learn more online: [www.ingimex.com/tippers](http://www.ingimex.com/tippers)

  
**INGIMEX**

# Mercedes Sprinter Tipper

Suitable for both carrying and tipping loads, the Ingimex tipper is a lightweight, high strength body with a market leading payload and designed to EN12642 XL & EN12640.

Designed and tested to the latest European standards, fitted with an array of features as standard, and easily adapted to allow for the addition of optional modifications; the Ingimex tipper is the perfect partner for your Mercedes Sprinter chassis.



DESIGNED, MANUFACTURED AND TESTED IN THE UK



COMES WITH A 3 YEAR INGIMEX WARRANTY AS STANDARD

Cab Style	Single	Double
Frame length	MWB	LWB
Rear Wheel	SRW	
(X) Wheelbase (mm)	3665	4325
(A) Internal Length (mm)	3119	3119
(B) Internal Width (mm)	2026	2026
(B) External Width (mm)	2087	2087
(C) Sideboard Height (mm)	400	400
(D) Tail-board Height (mm)	600	600
(E) Overall Length (mm)	5921	6733
Body Weight (kg)	500	506

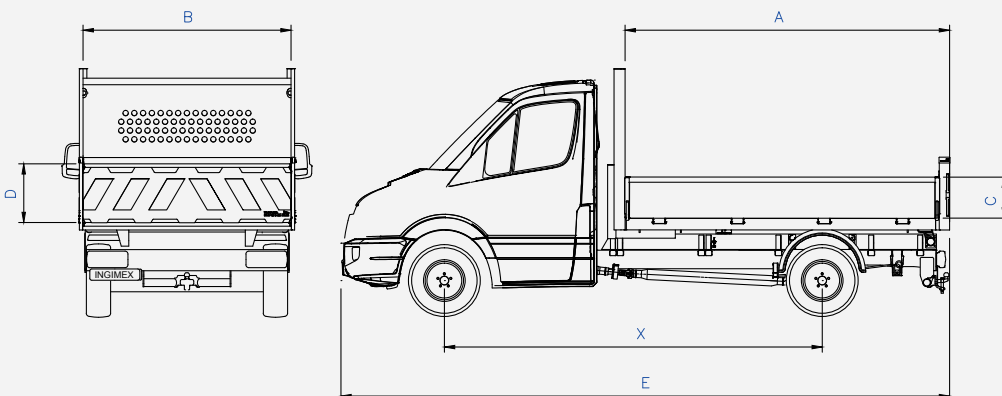

Learn more online: [www.ingimex.com/tippers](http://www.ingimex.com/tippers)

Wide range of optional extras available

Our Tipper bodies support a wide range of bolt-on modifications to suit your needs

[www.ingimex.com/options](http://www.ingimex.com/options)



[www.ingimex.com](http://www.ingimex.com)

+44 (0) 1952 585 833

[les@ingimex.com](mailto:les@ingimex.com)

