

Ford Transit Dropside



Learn more online: www.ingimex.com/dropsides

INGIMEX

Ford Transit Dropside

Suitable for general freight, the Ingimex Dropside is a low cost, lightweight, high strength body with a market leading payload designed to EN12642 XL & EN12640.

Designed and tested to the latest European standards, fitted with an array of features as standard, and easily adapted to allow for the addition of optional modifications; the Ingimex dropside is the perfect partner for your Ford Transit chassis.



DESIGNED, MANUFACTURED AND TESTED IN THE UK



COMES WITH A 3 YEAR INGIMEX WARRANTY AS STANDARD

Cab Style	Single				Double	
	L1	L2	L3	L4	L3	L4
Frame length						
Rear Wheel	SRW	DRW / SRW				
(X) Wheelbase (mm)	3137	3504	3954	3954	3954	3954
(A) Internal Length (mm)	2788	3155	3605	4162	2788	3345
(B) Internal Width (mm)	2114	2114	2114	2114	2114	2114
(B) External Width (mm)	2175	2175	2175	2175	2175	2175
(C) Sideboard Height (mm)	400	400	400	400	400	400
(D) Tail-board Height (mm)	400	400	400	400	400	400
(E) Overall Length (mm)	5447	5814	6264	6821	6264	6647
Body Weight (kg)	294	330	372	391	327	373

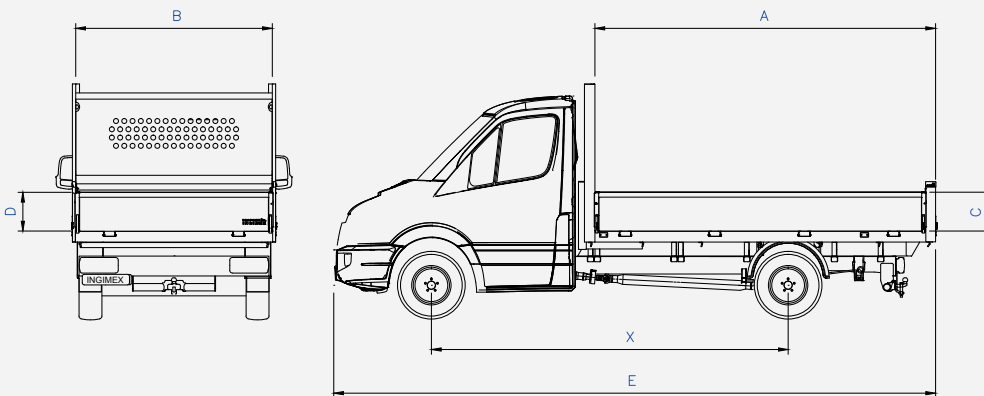

Learn more online: www.ingimex.com/dropsides

Wide range of optional extras available

Our Dropside bodies support a wide range of bolt-on modifications to suit your needs.

www.ingimex.com/options



www.ingimex.com +44 (0) 1952 585 833 sales@ingimex.com

