



Renault Luton van from Ingimex

- High payload
- Large number of features fitted as standard
- Whole body designed to latest European design standards
- Readily modified for the addition of a tail-lift
- 3 year warranty



Tel: +44 (0)1952 585833
Email: sales@ingimex.com
Website: www.ingimex.com



Renault Luton van

Features



- GRP sides & bulkhead with no visible fixings so a clear finish for livery.
- Bolted rear frame is dip painted and powder coated for top quality corrosion resistance.



- Uniquely Ingimex four-tier load restraint system.
- Allows for lashing to the deck, standard load lock lashing or for the use of the Ingimex telescopic load poles.



- Designed and manufactured by Ingimex; the high-strength shutter has no external cables and a smooth finish suitable for livery.
- A reinforced bottom plank to protect against movement of unsecured loads.



- Rear footsteps is fitted as standard.
- Full height grab handle has an integrated interior spot lamp which can be rotated by 360°.

Chassis Options

CAB STYLE	SINGLE CAB
FRAME LENGTH	L3
REAR WHEEL	SRW
(X) Wheel Base (mm)	4332
(A) Internal Length (mm)	4119
(B) Internal Width (mm)	1951
(B) External Width (mm)	2100
(C) Internal Height (mm)	2120
(D) Aperture Height (mm)	1755
(E) Overall Length (mm)	6767

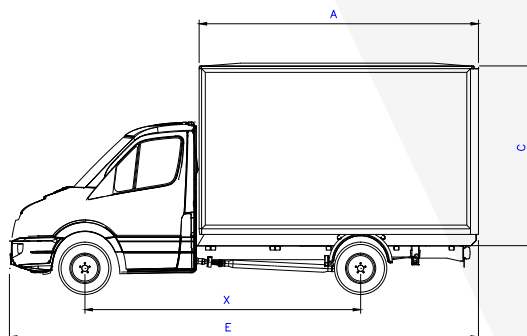
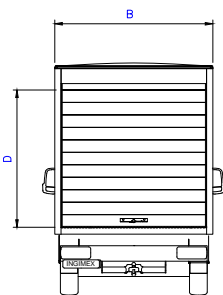

Optional extras

Ingimex offers a range of bolt on options to increase the functionality of your box van.



Ingimex load poles



500kg tail-lift installation



Livery

Tel: +44 (0)1952 585833
 Email: sales@ingimex.com
 Website: www.ingimex.com