



Peugeot Tipper from Ingimex

- High payload
- Large number of features fitted as standard
- Whole body designed to latest European design standards
- Bolted construction for fast and simple maintenance.
- 3 year warranty



Tel: +44 (0)1952 585833
Email: sales@ingimex.com
Website: www.ingimex.com



Peugeot Tipper

Features



- Smooth steel platform, optimised for torsional and bending strength.
- Whole platform dip e-coated providing long-life service.



- Three-level load lashing assembly.
- Bolted assembly with a 400kg gantry capacity.



- Seamless aluminium boards.
- Tail-board made from high yield steel with side mounted lock mechanisms.
- Wire rope supports retain tailboard horizontally and prevent rear lamp obstruction.



- Compact, under-floor lift mechanism with overload and hose burst protection.
- Mechanism designed to be maintenance free throughout vehicle life.

Chassis Options

CAB STYLE	SINGLE CAB	DOUBLE CAB
FRAME LENGTH	L2	L3
REAR WHEEL	SRW	SRW
(X) Wheel Base (mm)	3450	4035
(A) Internal Length (mm)	2870	2670
(B) Internal Width (mm)	2026	2026
(B) External Width (mm)	2087	2087
(C) Sideboard Height (mm)	400	400
(D) Tail-board Height (mm)	600	600
(E) Overall Length (mm)	5859	6100

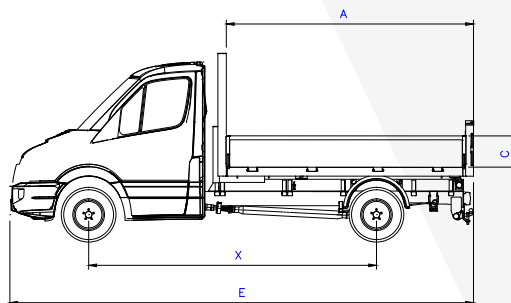
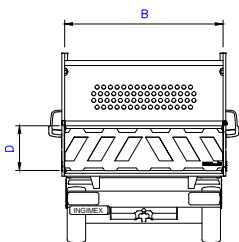

Optional extras

We offer a number of bolt-on options for the Ingimex tipper such as additional load restraint points, lighting beacons, operator safety equipment and steel storage boxes.



Ingimex tool trunk



Ingimex folding footstep



Grab handles



Ingimex tow bar installation

Tel: +44 (0)1952 585833
 Email: sales@ingimex.com
 Website: www.ingimex.com