



## Peugeot Dropside from Ingimex

- High payload
- Large number of features fitted as standard
- Whole body designed to latest European design standards
- Readily modified for the additional of arrest rails, tail-lifts etc.
- 3 year warranty



Tel: +44 (0)1952 585833  
Email: [sales@ingimex.com](mailto:sales@ingimex.com)  
Website: [www.ingimex.com](http://www.ingimex.com)



# Peugeot Dropside

## Features

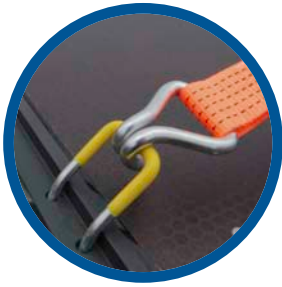

- One piece, 15mm thick birch non-slip deck.
- Recessed, wash down lashing rings, tested to 800kg.



- Three-level load lashing assembly.
- Bolted assembly with a 400kg gantry capacity.



- Seamless aluminium boards, perfect for livery.
- Boards and lock assemblies tested to a burst load of 1.7t.



- Removable, powder coated rear corner pillars extend above board height to form lateral stops.
- Wire rope supports retain tailboard horizontally and prevent rear lamp obstruction.

## Chassis Options

CAB STYLE	SINGLE CAB			DOUBLE CAB
	L2	L3	L4	L3
FRAME LENGTH				
REAR WHEEL	SRW	SRW	SRW	SRW
(X) Wheel Base (mm)	3450	4035	4035	4035
(A) Internal Length (mm)	3059	3644	4009	2805
(B) Internal Width (mm)	2026	2026	2026	2026
(B) External Width (mm)	2087	2087	2087	2087
(C) Sideboard Height (mm)	400	400	400	400
(D) Tail-board Height (mm)	400	400	400	400
(E) Overall Length (mm)	5645	6230	6595	6230

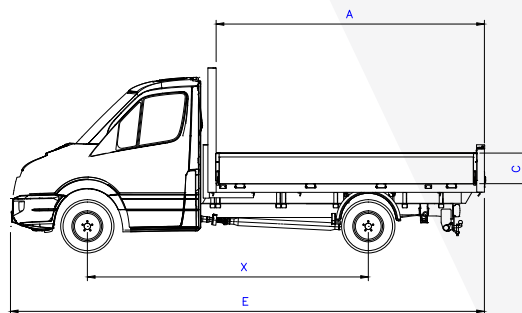
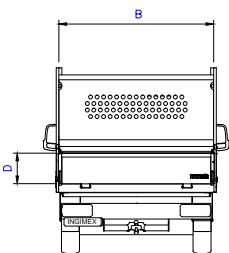

## Optional extras

Ingimex dropsides are highly adaptable. We offer a range of bolt on options such as additional load restraint points, lighting beacons, operator safety equipment, storage boxes and hydraulic lifting equipment.



Ingimex tool trunk



Ingimex folding footstep



Grab handles



Ingimex tail-lift installation

Tel: +44 (0)1952 585833  
 Email: [sales@ingimex.com](mailto:sales@ingimex.com)  
 Website: [www.ingimex.com](http://www.ingimex.com)