



Mercedes Tipper from Ingimex

- High payload
- Large number of features fitted as standard
- Whole body designed to latest European design standards
- Bolted construction for fast and simple maintenance.
- 3 year warranty



Tel: +44 (0)1952 585833
Email: sales@ingimex.com
Website: www.ingimex.com



Mercedes Tipper

Features



- Smooth steel platform, optimised for torsional and bending strength.
- Whole platform dip e-coated providing long-life service.



- Three-level load lashing assembly.
- Bolted assembly with a 400kg gantry capacity.



- Seamless aluminium boards.
- Tail-board made from high yield steel with side mounted lock mechanisms.
- Wire rope supports retain tailboard horizontally and prevent rear lamp obstruction.



- Compact, under-floor lift mechanism with overload and hose burst protection.
- Mechanism designed to be maintenance free throughout vehicle life.

Chassis Options

CAB STYLE	SINGLE CAB		DOUBLE CAB	
	M		M	L
VERSION	M		M	L
REAR WHEEL	SRW		SRW	SRW
(X) Wheel Base (mm)	3665		3665	4325
(A) Internal Length (mm)	3119		2469	3119
(B) Internal Width (mm)	2026		2026	2026
(B) External Width (mm)	2087		2087	2087
(C) Sideboard Height (mm)	400		400	400
(D) Tail-board Height (mm)	600		600	600
(E) Overall Length (mm)	5921		6013	6733

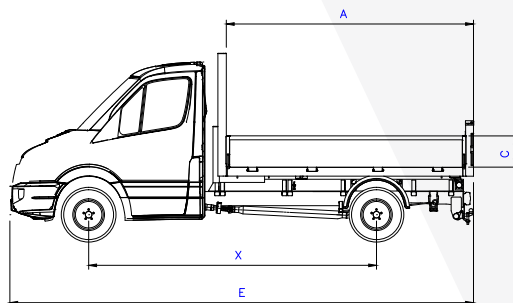
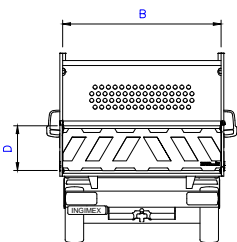

Optional extras

We offer a number of bolt-on options for the Ingimex tipper such as additional load restraint points, lighting beacons, operator safety equipment and steel storage boxes.



Ingimex tool trunk



Ingimex folding footstep



Grab handles



Ingimex tow bar installation

Tel: +44 (0)1952 585833
 Email: sales@ingimex.com
 Website: www.ingimex.com