



Mercedes Dropside from Ingimex

- High payload
- Large number of features fitted as standard
- Whole body designed to latest European design standards
- Readily modified for the additional of arrest rails, tail-lifts etc.
- 3 year warranty



Tel: +44 (0)1952 585833
Email: sales@ingimex.com
Website: www.ingimex.com



Mercedes Dropside

Features



- One piece, 15mm thick birch non-slip deck.
- Recessed, wash down lashing rings, tested to 800kg.



- Three-level load lashing assembly.
- Bolted assembly with a 400kg gantry capacity.



- Seamless aluminium boards, perfect for livery.
- Boards and lock assemblies tested to a burst load of 1.7t.



- Removable, powder coated rear corner pillars extend above board height to form lateral stops.
- Wire rope supports retain tailboard horizontally and prevent rear lamp obstruction.

Chassis Options

CAB STYLE	SINGLE CAB		DOUBLE CAB	
	M	L	M	L
VERSION				
REAR WHEEL	SRW	SRW	SRW	SRW
(X) Wheel Base (mm)	3665	4325	3665	4325
(A) Internal Length (mm)	3477	4287	2665	3475
(B) Internal Width (mm)	2026	2026	2026	2026
(B) External Width (mm)	2087	2087	2087	2087
(C) Sideboard Height (mm)	400	400	400	400
(D) Tail-board Height (mm)	400	400	400	400
(E) Overall Length (mm)	6183	6993	6181	6993

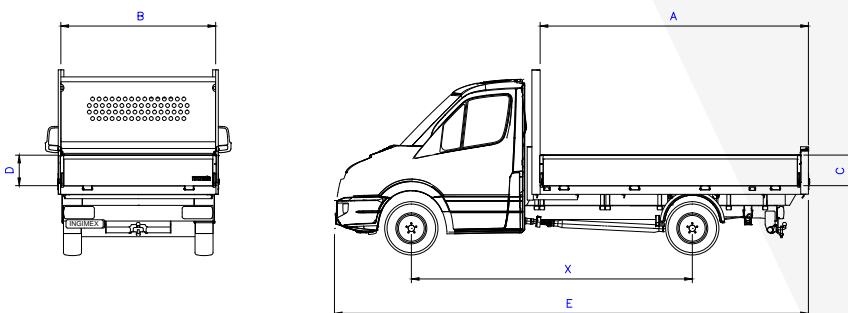

Optional extras

Ingimex dropside is highly adaptable. We offer a range of bolt on options such as additional load restraint points, lighting beacons, operator safety equipment, storage boxes and hydraulic lifting equipment.



Ingimex tool trunk



Ingimex folding footstep



Grab handles



Ingimex tail-lift installation

Tel: +44 (0)1952 585833
 Email: sales@ingimex.com
 Website: www.ingimex.com