



Ford Dropside from Ingimex

- High payload
- Large number of features fitted as standard
- Whole body designed to latest European design standards.
- Readily modified for the additional of arrest rails, tail-lifts etc.
- 3 year warranty



Tel: +44 (0)1952 585833
Email: sales@ingimex.com
Website: www.ingimex.com



Ford Dropside

Features

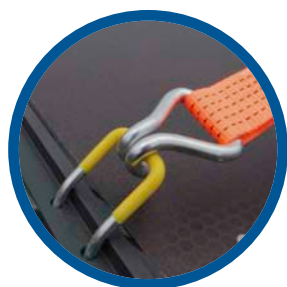

- One piece, 15mm thick birch non-slip deck.
- Recessed, wash down lashing rings, tested to 800kg.



- Three-level load lashing assembly.
- Bolted assembly with a 400kg gantry capacity.



- Seamless aluminium boards, perfect for livery.
- Boards and lock assemblies tested to a burst load of 1.7t.



- Removable, powder coated rear corner pillars extend above board height to form lateral stops.
- Wire rope supports retain tailboard horizontally and prevent rear lamp obstruction.

Chassis Options

CAB STYLE	SINGLE CAB				DOUBLE CAB		
	VERSION	300S	350M	350L	350EF	350L	350EF
REAR WHEEL	SRW	DRW	DRW	DRW	DRW	DRW	DRW
(X) Wheel Base (mm)	3137	3504	3954	3954 EF	3954	3954 EF	
Rear wheel	SRW	DRW	DRW	DRW	DRW	DRW	DRW
(A) Internal Length (mm)	2788	3155	3605	3988	2788	3171	
(B) Internal Width (mm)	2026	2026	2026	2026	2026	2026	
(B) External Width (mm)	2087	2087	2087	2087	2087	2087	
(C) Sideboard Height (mm)	400	400	400	400	400	400	
(D) Tail-board Height (mm)	400	400	400	400	400	400	
(E) Overall Length (mm)	5352	5719	6169	6552	6169	6552	

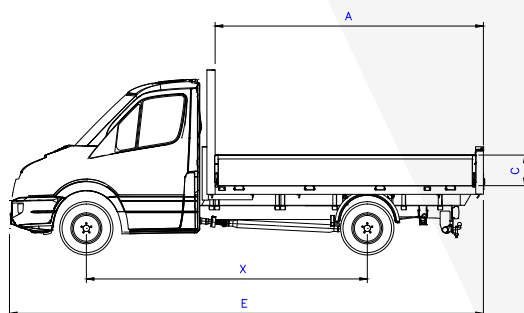
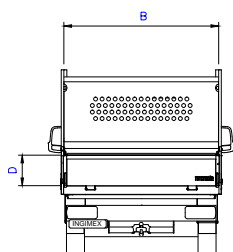

Optional extras

Ingimex dropsides are highly adaptable. We offer a range of bolt on options such as additional load restraint points, lighting beacons, operator safety equipment, storage boxes and hydraulic lifting equipment.



Ingimex tool trunk



Ingimex folding footstep



Grab handles



Ingimex tail-lift installation

Tel: +44 (0)1952 585833
 Email: sales@ingimex.com
 Website: www.ingimex.com